

MATERIAL LIST

SEQ No.	SEQ QTY	MILL LIST	MARK	QTY	DESCRIPTION	LENGTH	NOTES	STEEL GRADE
1	2	14A		2	ANGLE		E4	
		14A		2	L3x3x1/4	23 11/4		A36
					FIELD BOLTS			
					18 3/8 Dia EXP. ANCH.	0 4/2		
1	1	14B		ONE	ANGLE		E4	
		14B		1	L3x3x1/4	8 4/8		A36
					FIELD BOLTS			
					4 3/8 Dia EXP. ANCH.	0 4/2		
1	1	14D		ONE	ANGLE		E4	
		14D		1	L3x3x1/4	1 5		A36
					FIELD BOLTS			
					2 3/8 Dia EXP. ANCH.	0 4/2		
1	1	14E		ONE	ANGLE		E4	
		14E		1	L3x3x1/4	1 8/8		A36
					FIELD BOLTS			
					2 3/8 Dia EXP. ANCH.	0 4/2		

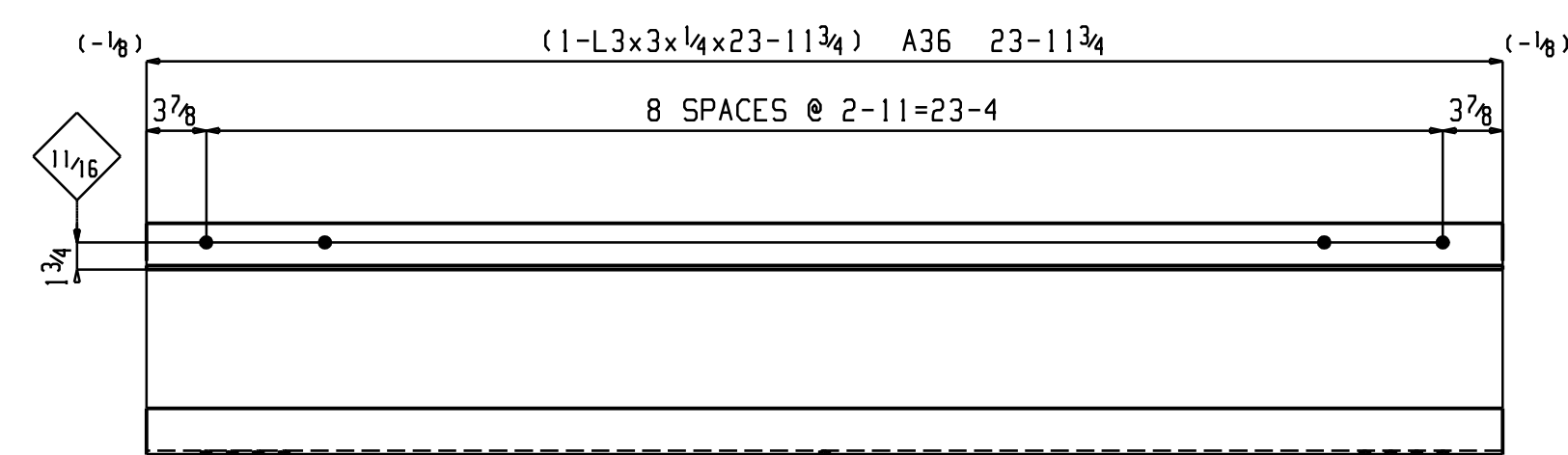

2 ANGLES 14A

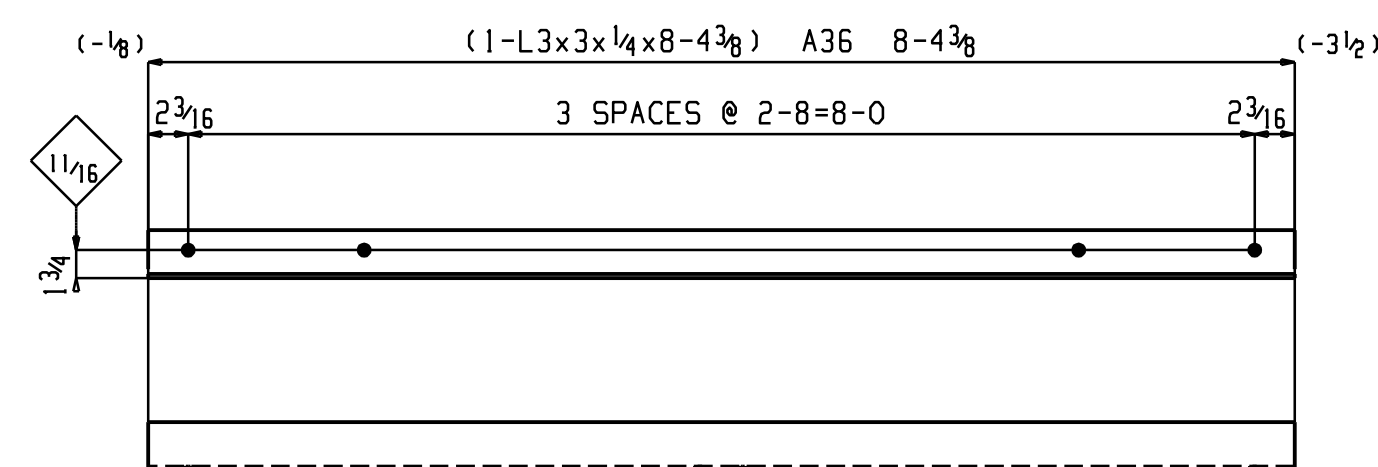

ONE ANGLE 14B

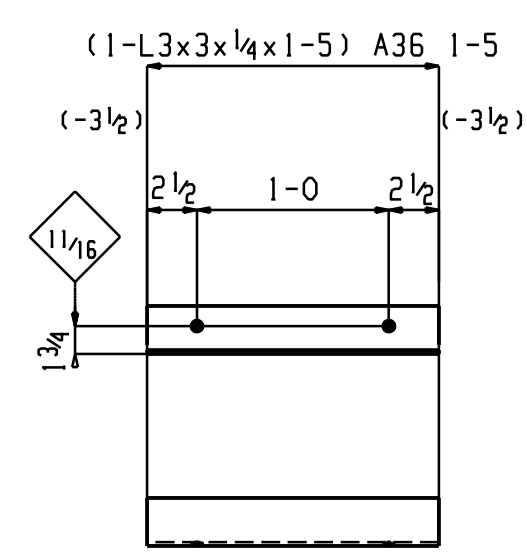

ONE ANGLE 14D

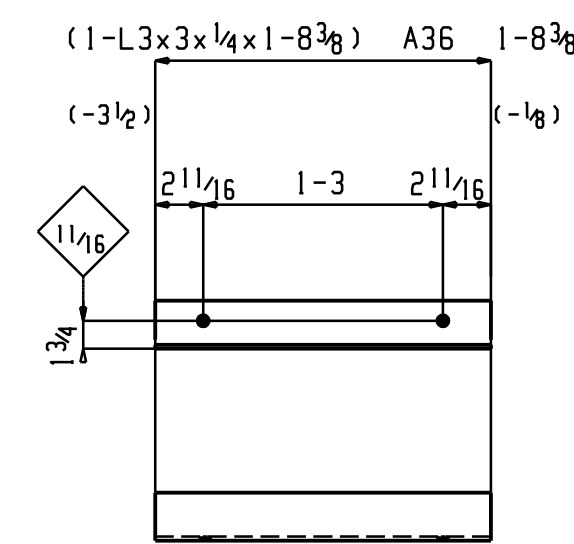

ONE ANGLE 14E

Sequence:	AS NOTED	Ref. E-Plans:	SEE NOTES COL.
Material:	AS NOTED	Edge Dist:	1 1/4" U.N.O.
Holes:	1 3/8 Dia.	Bolts:	3/4 Dia. A325 "TC"
Cleaning:	NONE		
Paint:	NONE		