

**ONE BEAM 34A**

W 18x38  
F 6x5/8

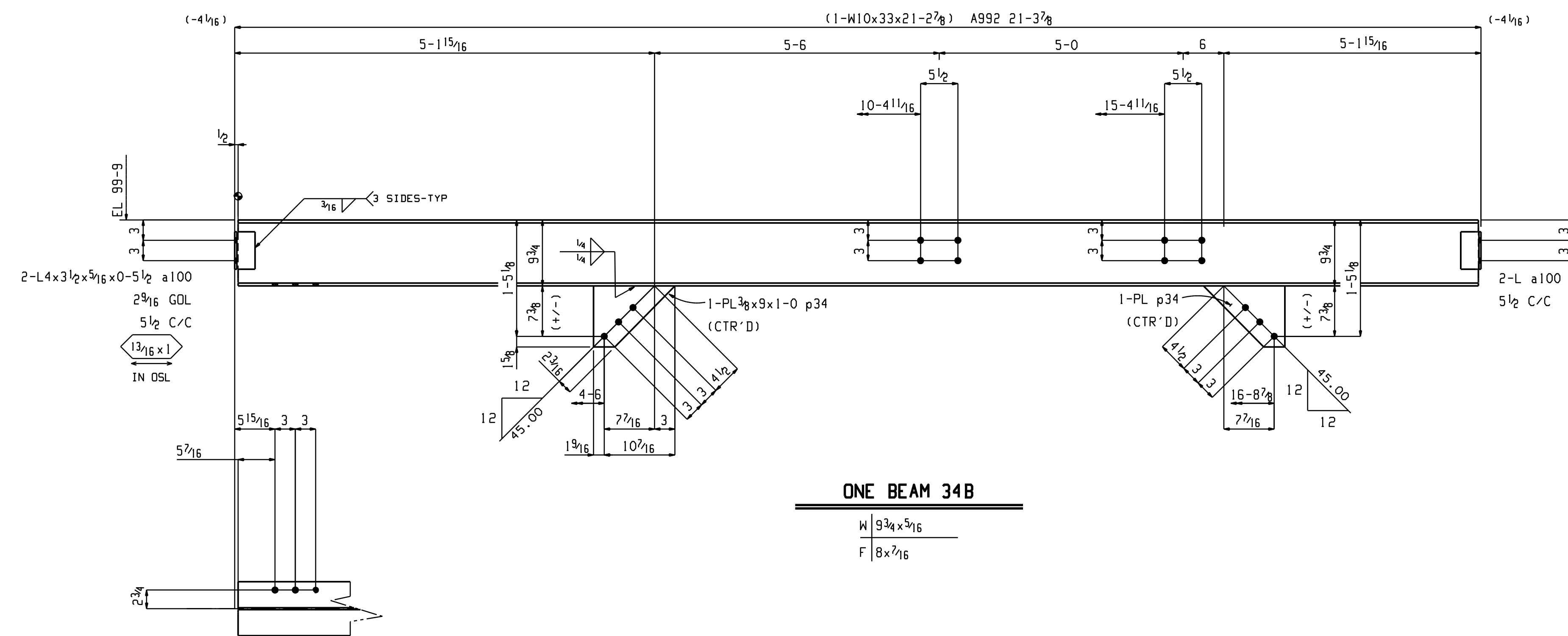

**ONE BEAM 34B**

W 9 3/4 x 5 1/16  
F 8 x 7/16

**MATERIAL LIST**

SEQ No.	SEQ QTY	MILL LIST	MARK	QTY	DESCRIPTION	LENGTH	NOTES	STEEL GRADE
1	1	34A		ONE BEAM			E1	
				1	W18x46	20' 9"		A992
				2	PL 3/8 x 13 3/4	1' 9"		A36
				8	L 4 x 3 x 5/16	0' 11 1/2"		A36
				2	PL 3/8 x 10 1/4	2' 9 1/2"		A36
					FIELD BOLTS			
				32	3/4 Dia A325	0' 2 1/4"	1HD WASH	
1	1	34B		ONE BEAM			E1	
				1	W10x33	21' 2 7/8"		A992
				4	L 4 x 3 1/2 x 5/16	0' 5 1/2"		A36
				2	PL 3/8 x 9	1' 0"		A36
					FIELD BOLTS			
				8	3/4 Dia A325	0' 2"	1HD WASH	

Sequence: AS NOTED Ref. E-Plans: SEE NOTES COL.  
 Material: AS NOTED Edge Dist: 1 1/4" U.N.O.  
 Holes: 1 3/16 Dia. Bolts: 3/4 Dia. A325 -TC-  
 Cleaning: NONE  
 Paint: NONE